

FIG. 1

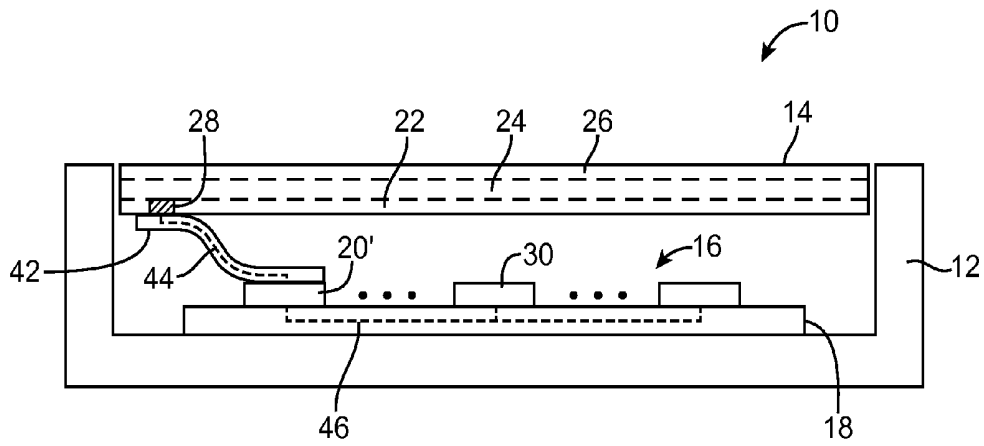

FIG. 2A

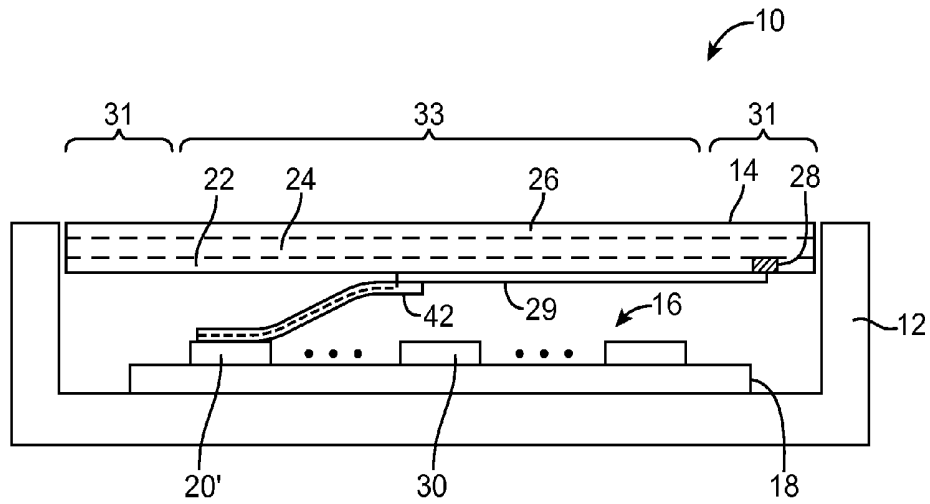

FIG. 2B

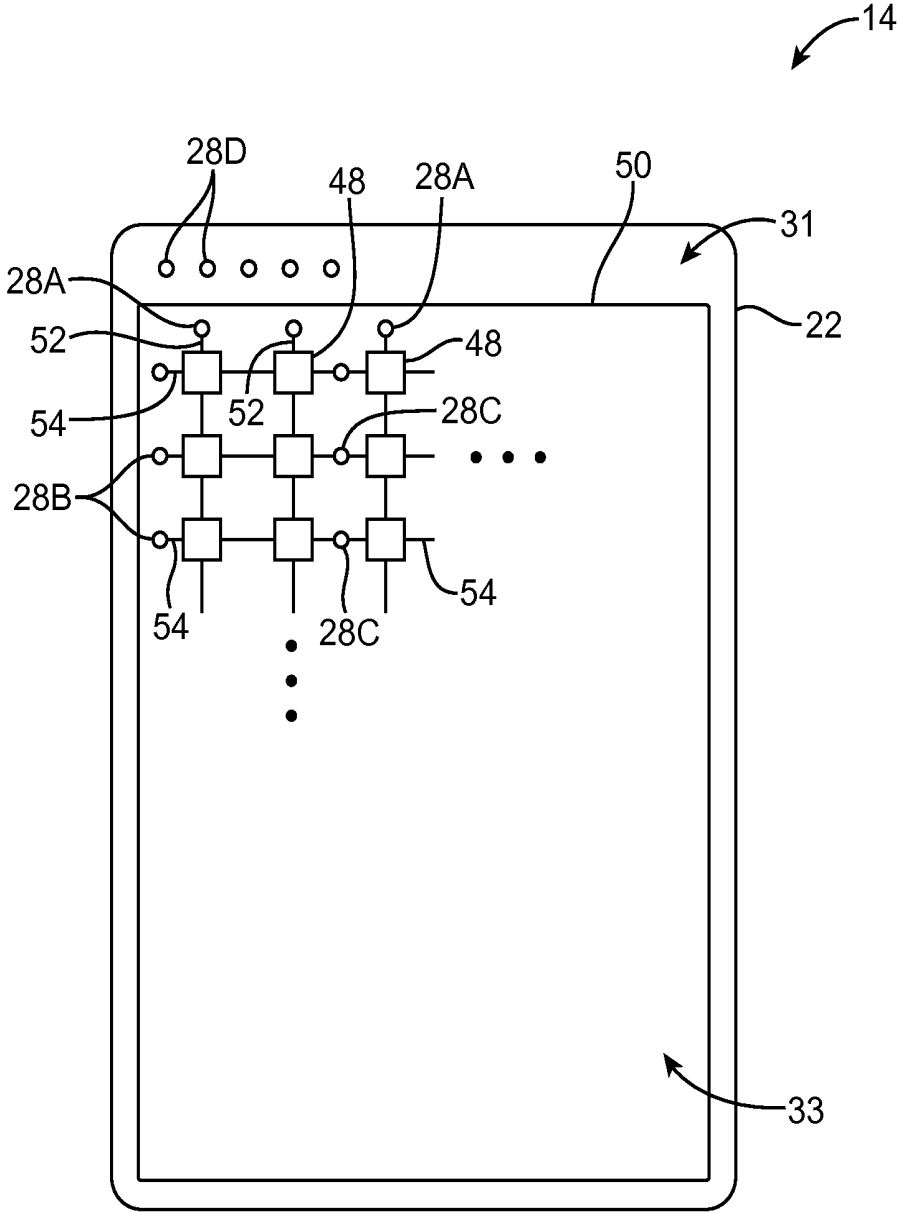

FIG. 3

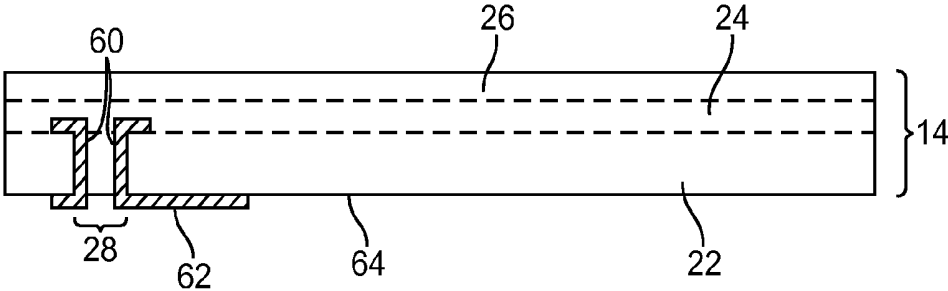

FIG. 4A

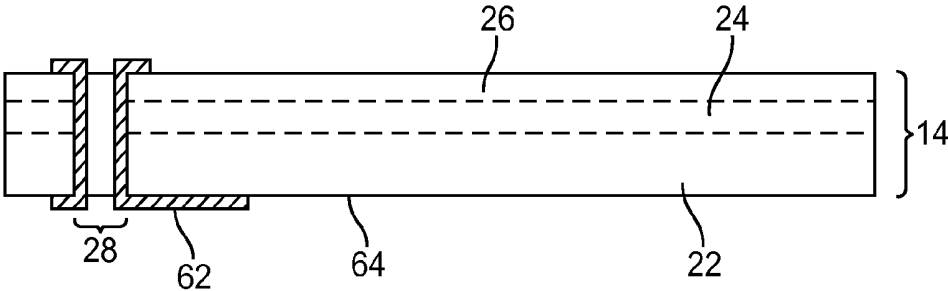

FIG. 4B

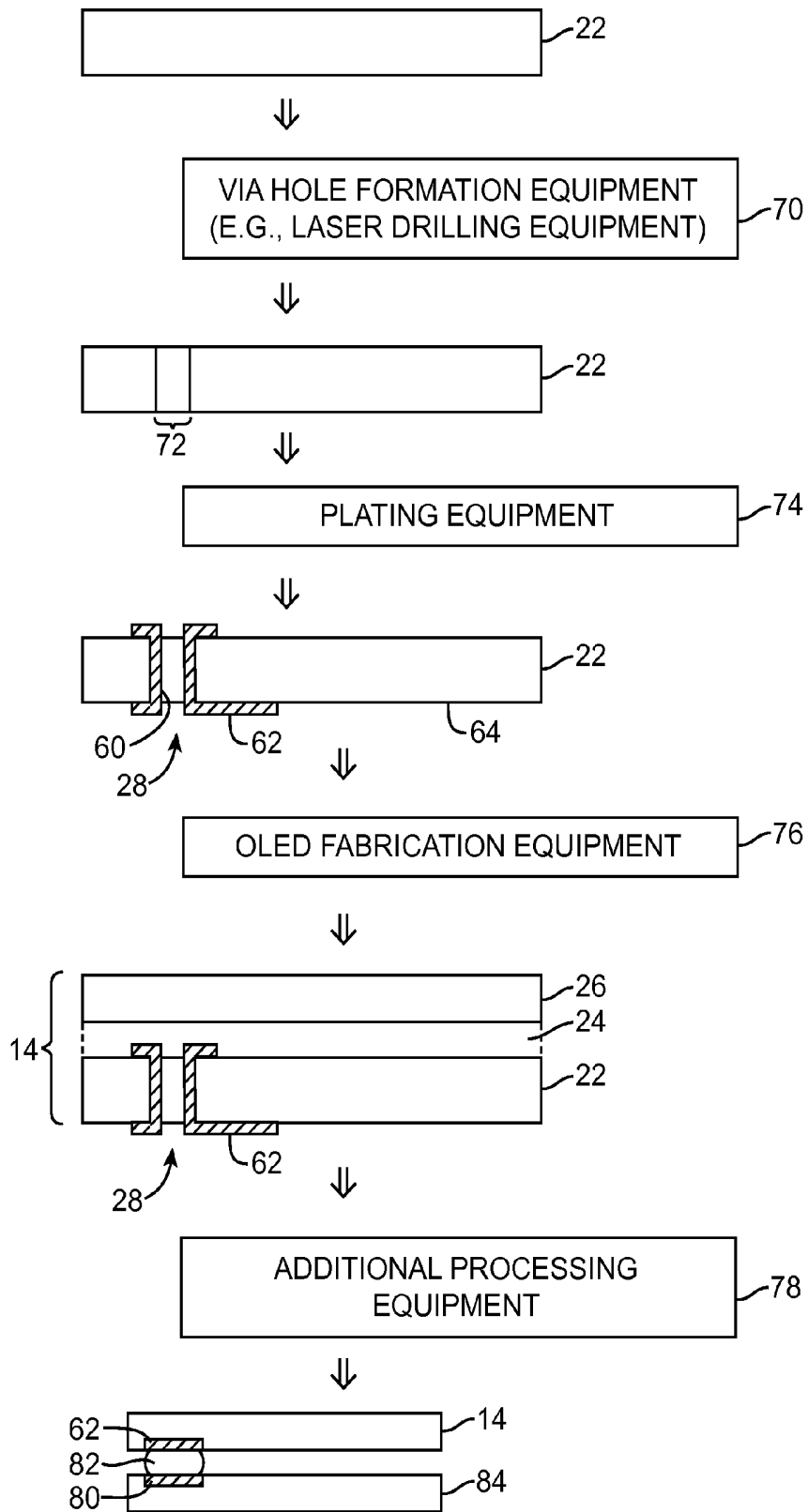

FIG. 5

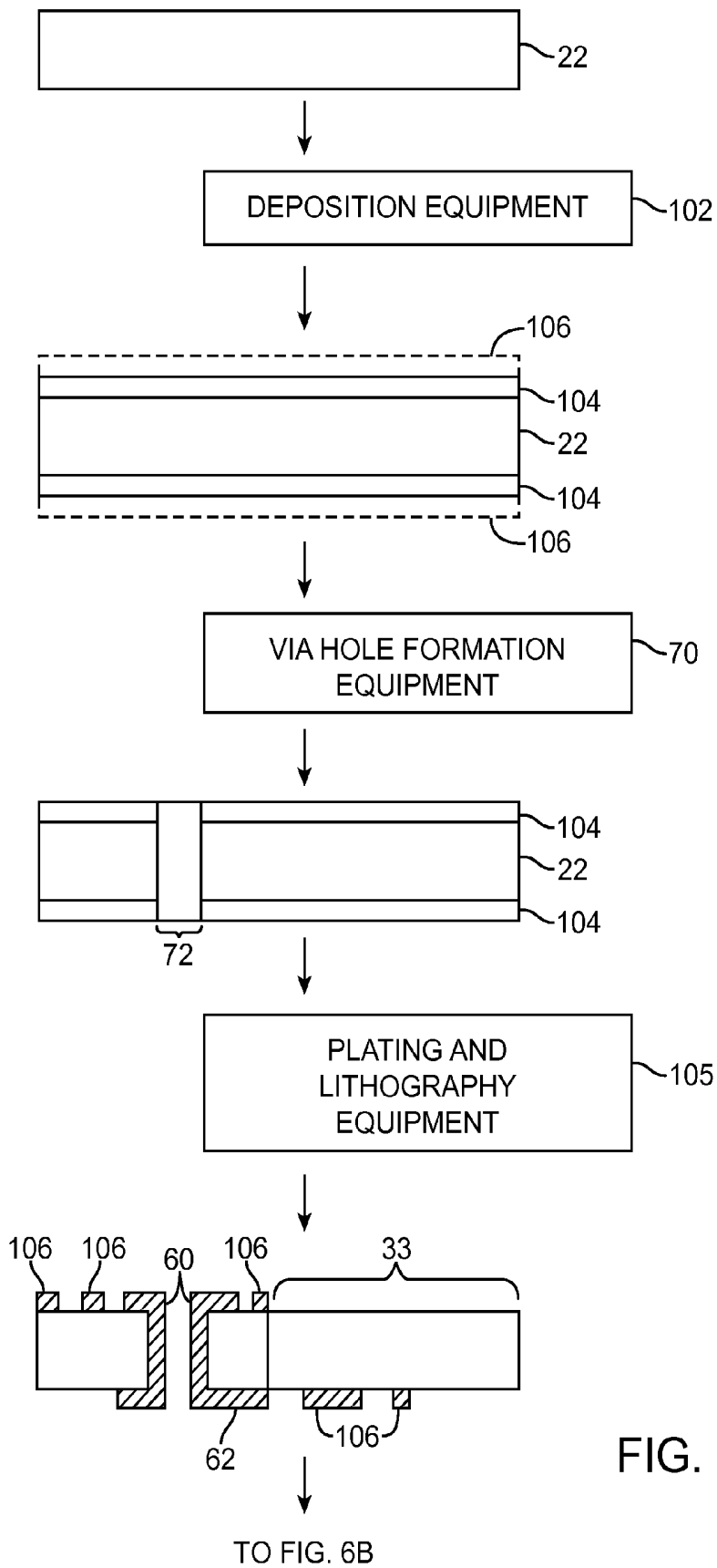

FIG. 6A

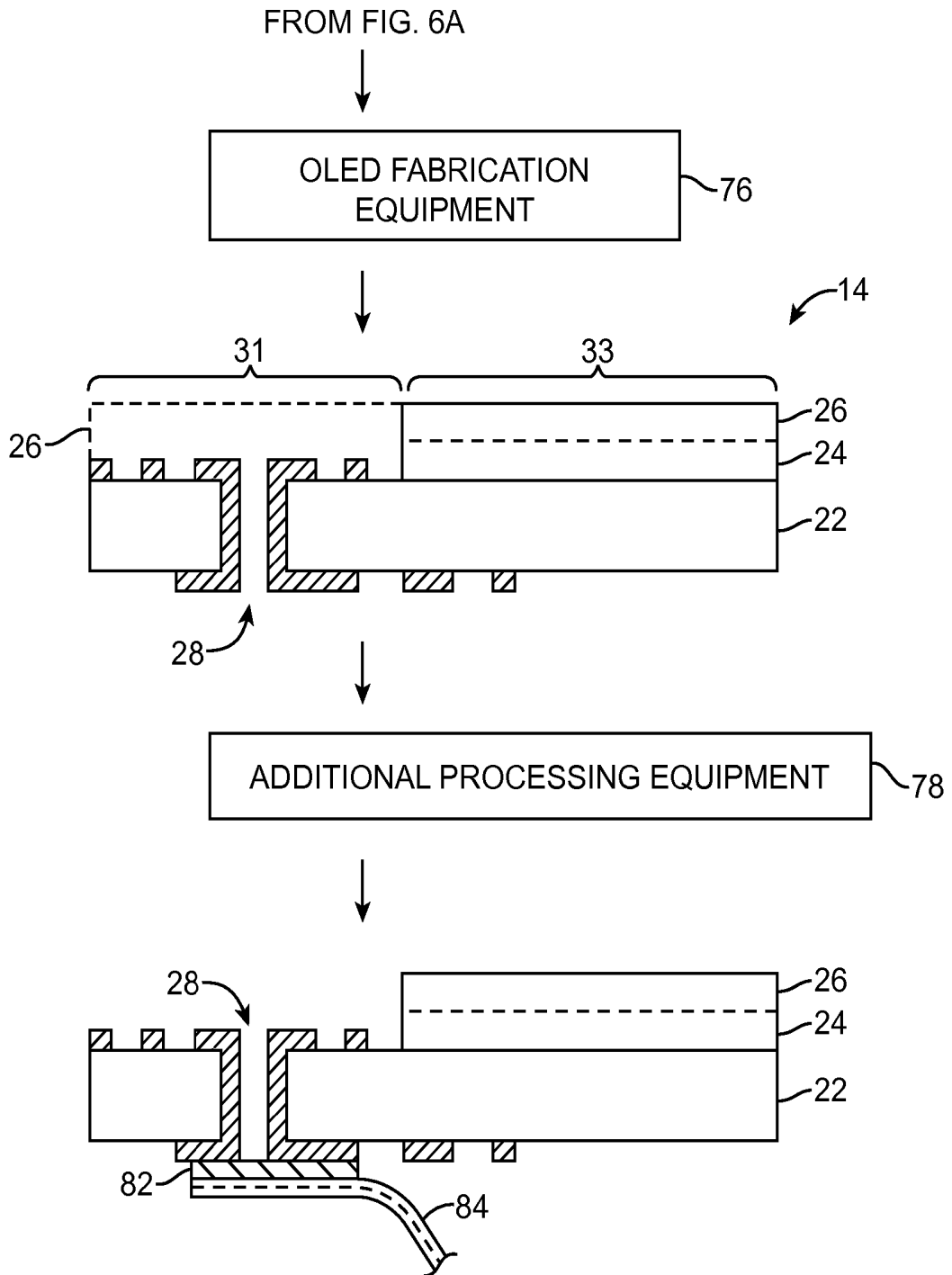

FIG. 6B

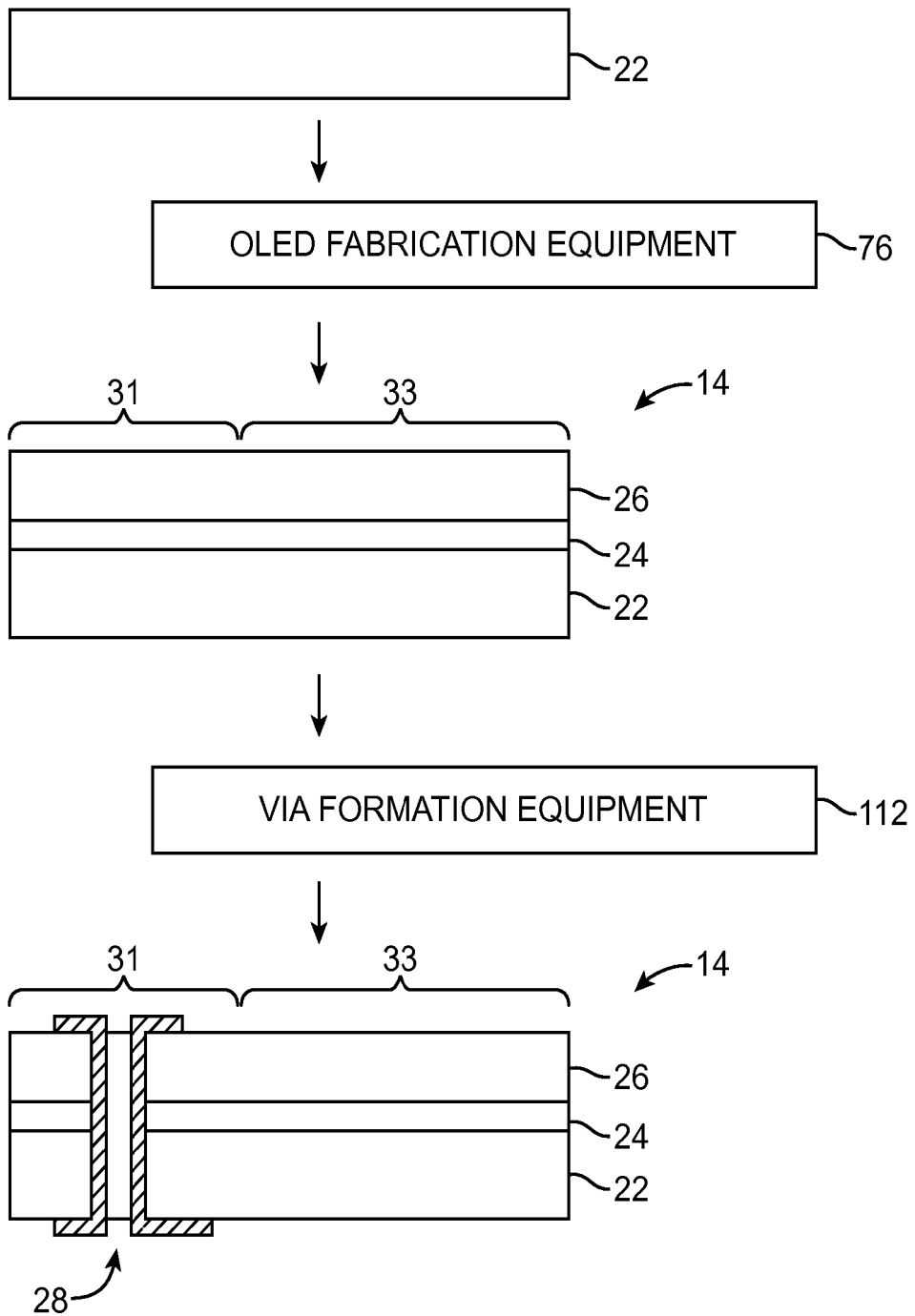

FIG. 7

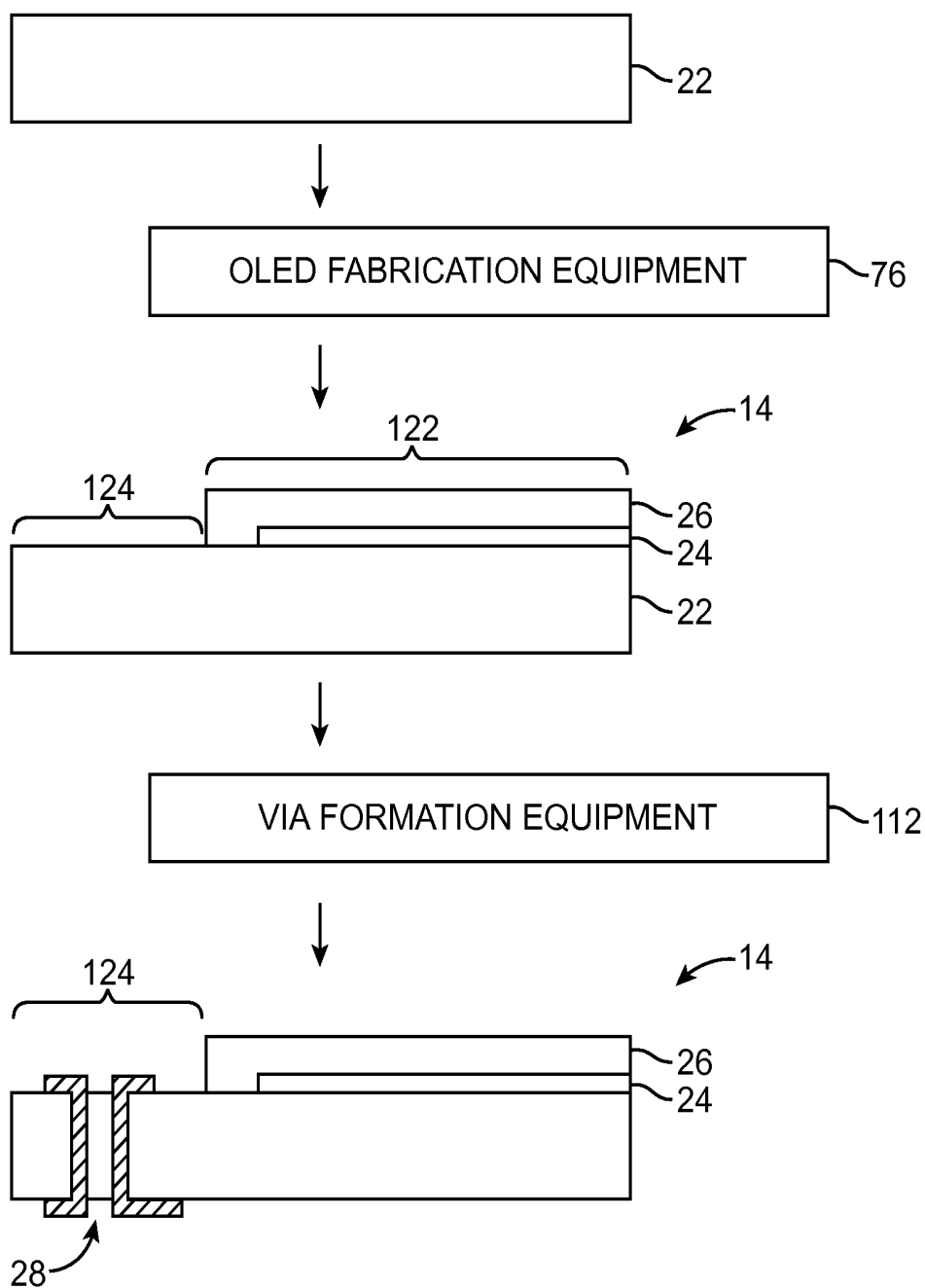

FIG. 8

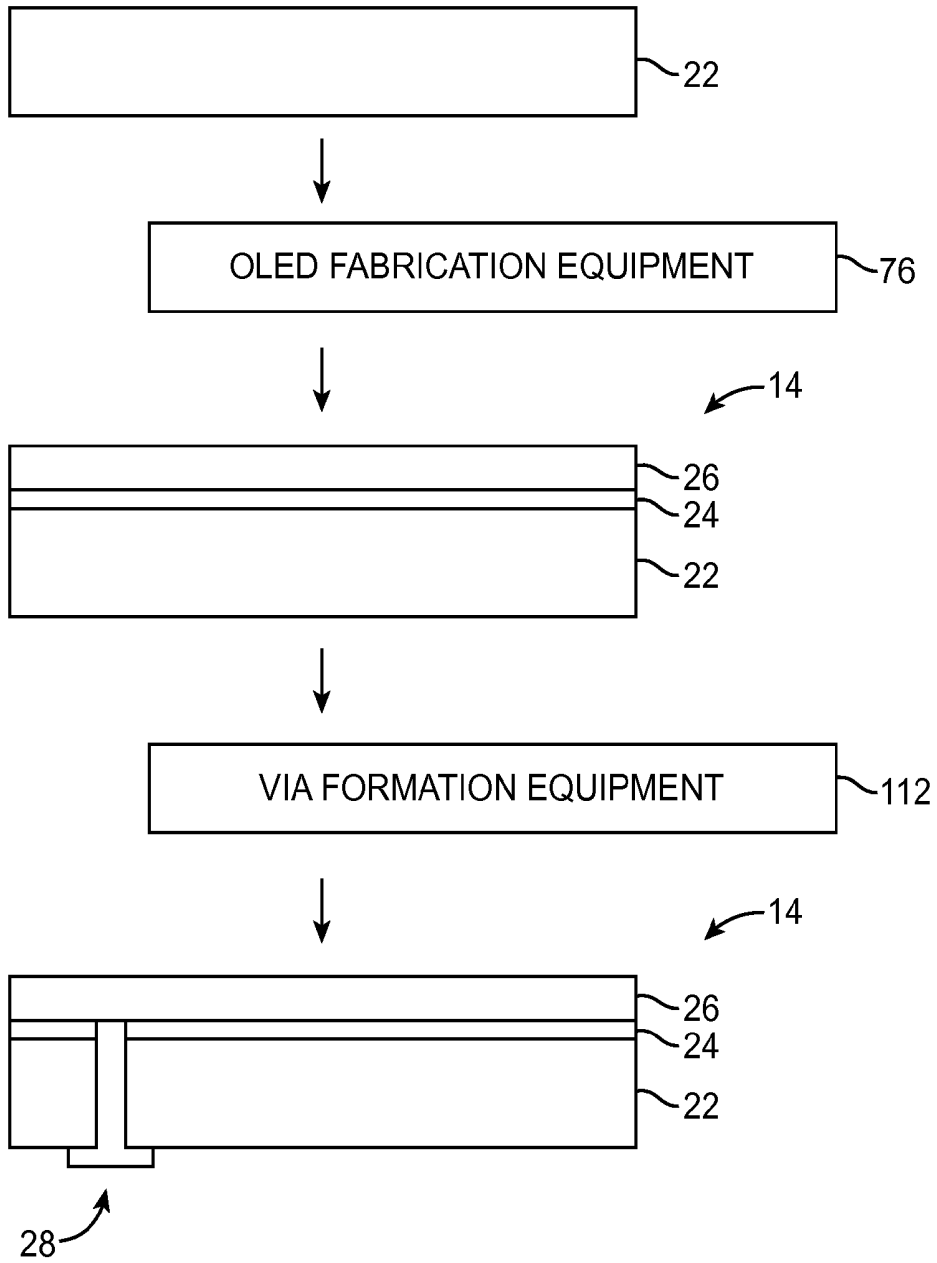

FIG. 9

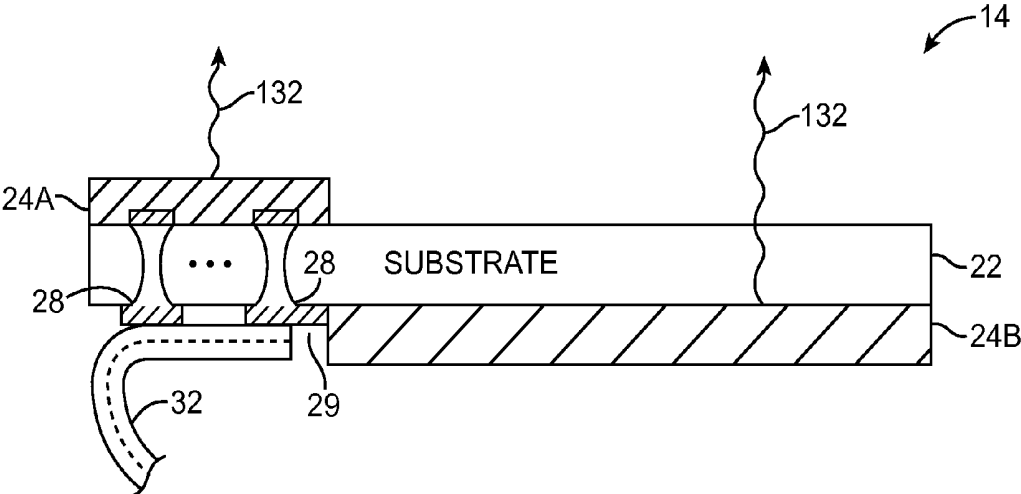

FIG. 10

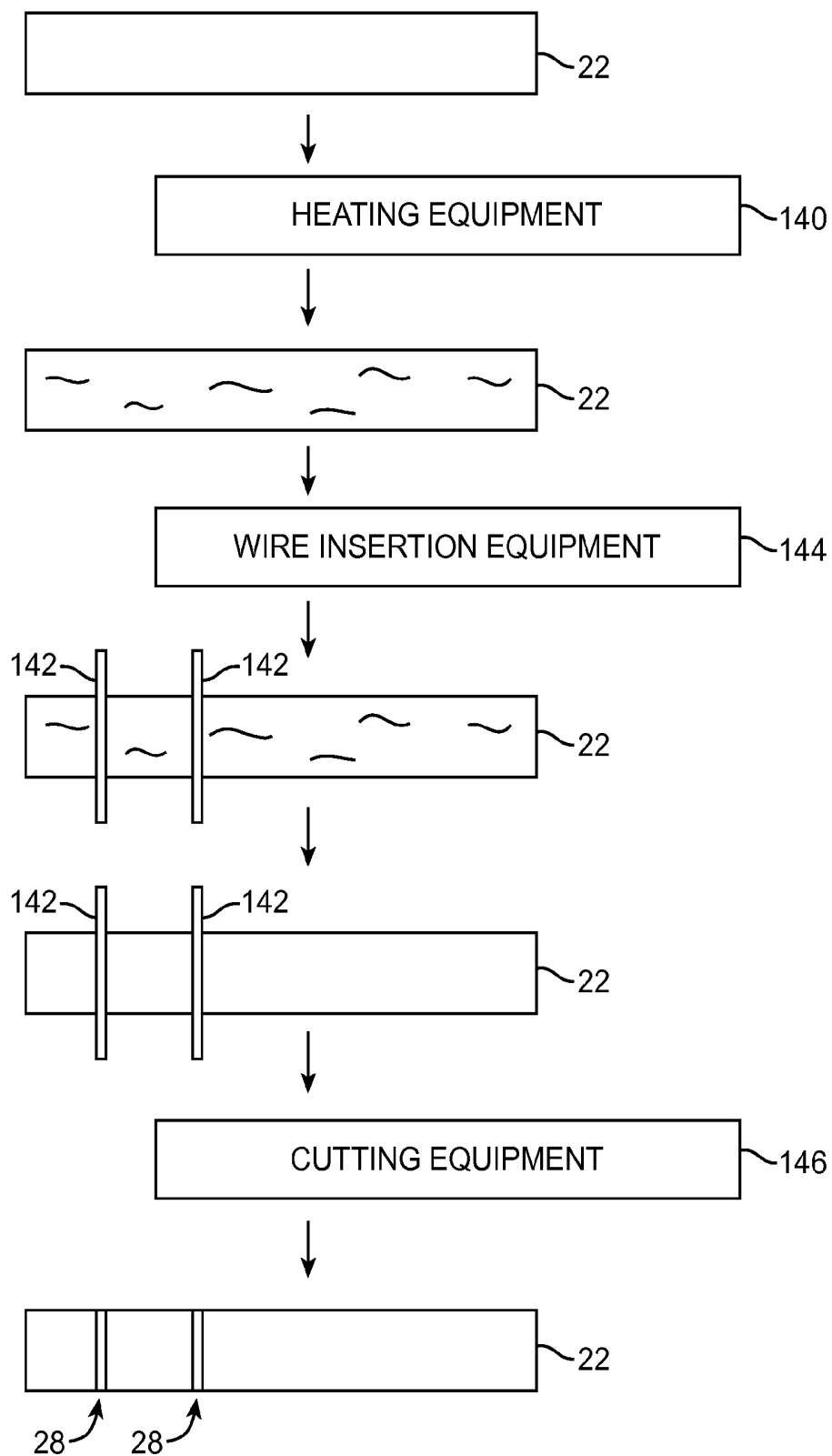

FIG. 11

## DISPLAYS WITH VIAS

[0001] This application is a division of U.S. patent application Ser. No. 13/766,657, filed Feb. 13, 2013, which claims the benefit of U.S. provisional patent application No. 61/664,060 filed Jun. 25, 2012. This application claims the benefit of and claims priority to U.S. patent application Ser. No. 13/766,657, filed Feb. 13, 2013, and U.S. provisional patent application No. 61/664,060 filed Jun. 25, 2012, which are hereby incorporated by reference herein in their entireties.

### BACKGROUND

[0002] This relates generally to electronic devices, and more particularly, to display for use in electronic devices.

[0003] Electronic devices such as portable computers and other electronic equipment may have displays. Driver circuitry may be used to control operation of the displays. In some displays, such as liquid crystal displays, a layer such as a thin-film transistor layer may have a ledge portion on which a display driver integrated circuit is mounted. The minimum size needed for the ledge is at least partly dictated by the size of the driver integrated circuit. In some device designs, such as designs for compact portable devices, the inclusion of this type of driver ledge may give rise to a border region for a liquid crystal display that is larger than desired. In other displays, driver circuitry may be coupled to the display using a flexible printed circuit cable. The attachment structures needed to accommodate attachment of the flexible printed circuit cable to the display may consume more area than desired, particularly in compact devices and in arrangements where thin display borders are desired.

[0004] It would therefore be desirable to provide improved ways to interconnect displays with associated circuitry such as display driver circuitry.

### SUMMARY

[0005] An electronic device may include thin film active devices such as a display. The display may be an organic light-emitting diode display. The organic light-emitting diode display may, for example, have a substrate layer, a layer of organic light-emitting diode structures, and a layer of sealant.

[0006] Vias may be formed in a display substrate layer by laser drilling, etching, or other via hole formation techniques. The vias may be formed before completion of the display or after completion of the display. The vias may be at least partially filled with a conductive material such as metal using electroplating or other metal deposition techniques. The vias may be connected to contacts on the rear surface of the display. Traces on the rear surface of the display may be used to route signals from the vias to desired locations on the rear surface of the display. Components such as flexible printed circuits, integrated circuits, connectors, and other circuitry may be mounted to the contacts on the rear surface of the display. Conductive materials such as solder and conductive adhesive may be used in mounting components to the contacts.

[0007] The display may include top surface emission portions (e.g., portions of the display that include light emission structures located at the top surface of the display) and bottom surface emission portions (e.g., having light emission structures at the bottom surface of the display that emit light from the top surface through the substrate). Vias may be formed in regions of the display substrate layer under the top surface emission portions. The vias may be coupled to the bottom

surface emission portions through traces formed on the bottom surface of the display substrate layer.

[0008] Vias in a display substrate layer may be formed by at least partially melting the display substrate layer and inserting wires, rods, or other conductive structures to form the vias. The display substrate layer may be subsequently cooled and excess via material may be removed.

[0009] Further features of the invention, its nature and various advantages will be more apparent from the accompanying drawings and the following detailed description.

### BRIEF DESCRIPTION OF THE DRAWINGS

[0010] FIG. 1 is a cross-sectional side view of an illustrative electronic device with a display having vias in accordance with an embodiment of the present invention.

[0011] FIG. 2A is a cross-sectional side view of an illustrative electronic device with a display having vias that are coupled to driver circuitry via a flexible printed circuit in accordance with an embodiment of the present invention.

[0012] FIG. 2B is a cross-sectional side view of an illustrative electronic device with a display having vias that are coupled to driver circuitry via a flexible printed circuit that is attached to a central portion of the display in accordance with an embodiment of the present invention.

[0013] FIG. 3 is a top view of an illustrative display showing how vias may be used in distributing signals for the display in accordance with an embodiment of the present invention.

[0014] FIG. 4A is a cross-sectional side view of a portion of a display showing how a via may be formed through the rear surface of the display in accordance with an embodiment of the present invention.

[0015] FIG. 4B is a cross-sectional side view of a portion of a display showing how a via may be formed extending through front and rear surfaces of the display in accordance with an embodiment of the present invention.

[0016] FIG. 5 is a diagram showing how a display may be provided with vias so that circuitry can be attached to the rear of the display in accordance with an embodiment of the present invention.

[0017] FIGS. 6A-6B are diagrams showing how a display may be provided with vias and traces in accordance with an embodiment of the present invention.

[0018] FIG. 7 is a diagram showing how a via may be formed through multiple layers of a display in accordance with an embodiment of the present invention.

[0019] FIG. 8 is a diagram showing how a via may be formed through an exposed portion of a display substrate in accordance with an embodiment of the present invention.

[0020] FIG. 9 is a diagram showing how a blind via may be formed in a display in accordance with an embodiment of the present invention.

[0021] FIG. 10 is an illustrative display having top and bottom emission regions in accordance with an embodiment of the present invention.

[0022] FIG. 11 is a diagram showing how vias may be formed in a display by partially melting a display substrate in accordance with an embodiment of the present invention.

### DETAILED DESCRIPTION

[0023] Electronic devices may be provided with displays having vias. An illustrative electronic device of the type that may be provided with a display having vias is shown in FIG.

1. Electronic device **10** of FIG. **1** may be a computer, a personal computer, a tablet computer, a cellular telephone, a media player, a gaming device, a navigation device, or other electronic equipment. As shown in the cross-sectional view of device **10** in FIG. **1**, electronic device **10** may include housing **12**, a display such as display **14**, and internal components such as components **16**.

[0024] Housing **12** may be formed from plastic, metal, fiber-composite materials, glass, ceramic, other materials, or combinations of these materials. Display **14** may be a liquid crystal display, an organic light-emitting diode display, a plasma display, an electrochromic display, an electrophoretic ink display, an electrowetting display, or other suitable display. Examples in which display **14** is implemented as an organic light-emitting diode display are sometimes described herein as an example. This is, however, merely illustrative. Display **14** may be formed using any suitable display if desired. If desired, display **14** may be covered with a cover layer of glass or plastic or other protective display layer. In the example of FIG. **1**, a cover layer has been omitted.

[0025] Internal components **16** may include printed circuits such as circuits on rigid printed circuit boards (e.g., fiber-glass-filled epoxy printed circuit boards), flexible printed circuits ("flex circuits") formed from flexible sheets of polymers such as polyimide, "rigid flex" printed circuits (e.g., printed circuit boards including rigid printed circuit portions with integral flex circuit tails), or other printed circuit structures. As an example, device **10** may include a printed circuit such as printed circuit board **18** on which one or more components such as electrical components **20** or other internal components **16** have been mounted. Components **20** may include switches, connectors, discrete components such as capacitors, resistors, and inductors, integrated circuits such as general purpose processors or application-specific integrated circuits, and other electronic components.

[0026] As shown in FIG. **1**, display **14** may have multiple layers. Display **14** may be an organic light-emitting diode display including substrate layer **22**, a layer of thin-film transistor structures (e.g., polysilicon transistors and/or amorphous silicon transistors) and organic emissive material such as layer **24**, and a sealant layer such as layer **26**. Substrate layer **22** may be formed from a rigid or flexible dielectric such as glass, ceramic, plastic, or other dielectric materials. As an example, substrate **22** in display **14** may be formed from a flexible sheet of polymer such as a layer of polyimide. If desired, substrate **22** may be formed from transparent materials such as sapphire, glass, plastics, transparent acrylics, or other transparent materials.

[0027] Vias such as vias **28** may be formed in display **14**. As shown in FIG. **1**, for example, vias **28** may be formed through substrate layer **22** so that electrical contacts may be formed on the rear (i.e., inner or bottom) surface of substrate **22** and display **14**. Vias **28** may, if desired, be formed through multiple layers of display **14**. For example, vias **28** may be formed extending through layer **22** and portions of layer **24**. As another example, vias **28** may extend through layers **22**, **24**, and **26** of display **14**.

[0028] Vias **28** may be formed by drilling and electroplating or using other via fabrication techniques. For example, via holes may be formed using a laser drill or a mechanical drill. As another example, etching tools may be used to etch via holes in display layers such as substrate layer **22**.

[0029] Conductive material in vias **28** such as metal may be used to form signal paths in display **14**. The signal paths of

display **14** may, for example, be used to route signals between the circuitry of layer **24** (e.g., thin-film transistors, organic semiconductor circuitry, oxide transistors, etc.) and external circuitry such as display driver circuitry. Conductive materials used to form vias **28** may include copper, titanium, molybdenum, indium, palladium, rhodium, chromium, gold, silver, platinum, combinations of these materials, or other conductive materials. For example, gold-plated copper may be deposited to cover via holes. Conductive materials such as copper or other heavy metals that are used to form vias **28** may be coated with a protective layer of materials such as titanium, gold, or chromium to help prevent diffusion to neighboring materials (e.g., to protect neighboring materials from being contaminated).

[0030] In the example of FIG. **1**, display driver integrated circuit **30** may provide control signals such as gate driver signals for circuitry on display **14**. Display driver integrated circuit **30** (in the FIG. **1** example) may be mounted on printed circuit **32**. Printed circuit **32** may be a rigid printed circuit board, a flex circuit, or a rigid flex circuit. For example, printed circuit **32** may be a flex circuit that includes one or more layers of patterned interconnect lines such as traces **34**. Traces **34** may be electrically coupled between one or more vias in substrate layer **22** of display **14** and driver integrated circuit **30**. If desired, traces **34** may be coupled to a communications path formed from flex circuit **36** (e.g., a flex circuit that is connected to printed circuit board **18** directly or, as shown in FIG. **1**, a flex circuit that is connected to components **20** on printed circuit board **18** via flex circuit connector **20'**). The connection between flex circuit **36** and printed circuit **32** may be formed using a connector or by directly attaching (e.g., mounting) flex circuit **36** to traces **34** on printed circuit **32**.

[0031] Vias **28** may convey control signals from display driver circuit **30** to circuitry such as transistor structures in light-emitting layer **24**. By using vias **28** in display layers such as layers **22**, **24**, and/or **26**, the need to form flex circuit attachments or driver circuit attachments to the front (upper/exterior) surface of display **14** may be avoided, allowing the edge regions surrounding the active display pixels in display **14** to be minimized. More area in display **14** may therefore be available for forming the array of pixels that displays images to a user (e.g., for forming an active region of display **14**).

[0032] If desired, a jumper structure such as structure **38** may be attached to vias on the rear surface of substrate **22** and may be used to route signals between two or more different locations in display **14**. Structure **38** may be formed from a printed circuit such as a flex circuit or rigid printed circuit board. Traces **40** in structures **38** may be used to help distribute signals for display **14**. Any suitable signals may be routed through flex circuits or other jumper structures on the rear of display **14**. For example, structures **38** may be used to carry gate line signals, data line signals, power supply signals, or other information or power signals associated with operating display **14**. By implementing at least some of the interconnect resources associated with display **14** using structures located on the rear surface of display **14**, more room may be made available on the front surface of display **14** for active pixel structures and the size of any inactive border regions on the front side of display **14** may be minimized.

[0033] Structure **38** may, if desired, be formed by depositing conductive materials on the rear of display **14**. For example, deposition equipment may be used to deposit conductive materials such as copper, titanium, molybdenum,

indium, palladium, rhodium, gold, silver, platinum, or other conductive materials on the rear surface of display 14. The conductive materials may be deposited using deposition techniques such as chemical vapor deposition (CVD), metalorganic chemical vapor deposition (MOCVD), physical vapor deposition (PVD), atomic layer deposition (ALD), or other desired deposition techniques. The conductive materials may be patterned (e.g., using lithography equipment) to form traces for routing display signals.

[0034] In the illustrative arrangement of FIG. 1, printed circuit 32 is being used to support display driver integrated circuit 30 and separate flex circuit 36 is being used to convey signals on printed circuit 32 to printed circuit board 18 (via connector 20'). Other arrangements may be used if desired. For example, flex circuit 32 may be mounted directly to traces on printed circuit board 18 (e.g., using anisotropic conductive film or solder connections) or printed circuit 32 may be a flex circuit that is connected directly to connector 20' (e.g., omitting flex circuit 36). Additional flex circuits (not shown) on the rear surface of display 14 may be interconnected between vias 28 and circuitry such as circuitry in components 20 on printed circuit board 18. The additional flex circuits may, if desired, include supplemental interconnect lines for forming gate line paths, data line paths, power lines paths, or other signal paths in device 10. Supplemental interconnect lines for forming gate line paths, data line paths, power lines paths, or other signal paths in device 10 may also be formed using jumper structures 38 or by forming traces on the rear of display 14.

[0035] As shown in FIG. 2A, a printed circuit that is mounted to the rear surface of display 14 such as flex circuit 42 may include traces 44 that form signal paths between vias 28 in substrate 22 of display 14 and circuitry on printed circuit board 18. Connector 20' on printed circuit board 18 may be coupled to flex circuit 42 and convey signals from flex circuit 42 to traces 46 on printed circuit board 18. This example is merely illustrative. Flex circuit 42 may, if desired, be directly mounted to printed circuit board 18 using solder, anisotropic conductive film, conductive pastes so that traces 44 are electrically coupled to traces on printed circuit board 18 such as traces 46. Display driver circuitry 30 may be mounted on printed circuit board 18 and may convey control and/or data signals to display 14 via traces 46, 44 and vias 28.

[0036] Flex circuit 42 may be mounted underneath a central active region 33 as shown in FIG. 2B. Traces 29 formed on the rear of display 14 may be used to route display signals to a desired location on the rear of display 14. Display 14 may include inactive regions 31 (e.g., regions that do not include active pixels) located at the periphery of active region 33 (e.g., a region with active pixels). In the example of FIG. 2B, traces 29 may be used to convey display signals from vias 28 located in inactive regions 31 to a location beneath active region 33. Flex circuit 42 may be used to convey the display signals between traces 29 and circuitry such as display driver 30 on printed circuit board 18 via connector 20'.

[0037] In some scenarios, it can be challenging to route display signals from circuitry in central active regions to peripheral inactive regions, especially when multiple routing paths are required within a limited amount of available routing space or area. To reduce the number of routing paths required between central regions and peripheral regions of display 14, vias may be formed within the central regions.

FIG. 3 is an illustrative diagram of a display 14 including vias 28 (e.g., vias 28A, 28B, and 28C) that are formed within central active region 33.

[0038] As shown in FIG. 3, display 14 may include display pixels 48 in active region 33. Display pixels 48 may each contain one or more organic light-emitting diode structures for emitting light. Display pixels 48 may be organized in an array such as array 50. Array 50 may contain any suitable number or rows and columns of display pixels 48. For example, array 50 may have hundreds of rows and/or hundreds of columns of display pixels 48 (as an example). Vertical and horizontal control lines may be used in supplying control signals to display pixels 48. For example, signals may be applied to respective columns of display pixels 48 using vertical signal lines such as lines 52 and may be applied to respective rows of display pixels 48 using horizontal signal lines such as lines 54.

[0039] Signal lines 52 and 54 may be coupled to vias 28A and 28B. Vias such as vias 28C may be formed within array 50 (e.g., at intermediate locations in the rows or columns of display pixels 48). Edge vias such as vias 28D that are formed in inactive region 31 may be used for handling signals associated with operating display pixels 48 (e.g., signals for lines 52 and/or 54). Vias 28A, 28B, 28C, and 28D may be formed within substrate layer 22 of display 14 or spanning multiple layers of display 14 (e.g., substrate layer 22, layer 24, and/or layer 26).

[0040] A cross-sectional side view of a portion of display 14 containing a via 28 is shown in FIG. 4A. Via 28 may be one of vias 28 of FIGS. 1 and 2, one of vias 28A, 28B, 28C, or 28D of FIG. 3, or other vias formed through substrate 22 of display 14. As shown in FIG. 4A, via 28 may include tubular metal sidewalls such as sidewalls 60 that form a cylindrical inner surface of a through hole in layer 22. Sidewalls 60 may be formed using any desired fabrication technique. For example, sidewalls 60 may be formed using electrodeposition (e.g., formation of a thin seed layer followed by electroplating of a metal such as copper and, if desired, a subsequent coating of a metal such as gold). With a via structure of the type shown in FIG. 4A, via 28 is formed from a hole (e.g., a cylindrical hole) in substrate 22 that is lined with a tubular layer of metal. Other types of vias may be formed in layer 22 if desired (e.g., via holes that are plugged with solid metal, etc.).

[0041] If desired, traces may be formed on the surface of substrate 22. As shown in FIG. 4A, for example, contact pad 62 may be formed on rear surface 64 of display 14. Contact 62 may be formed from a metal trace that contacts and is electrically shorted to sidewalls 60 of via 28. Additional patterned conductive structures may be formed on surface 64 of substrate 22 if desired (e.g., conductive structures such as traces 29 of FIG. 2B). The example of FIG. 4A is merely illustrative.

[0042] Vias such as via 28 may be formed to span multiple layers of a display. FIG. 4B is an illustrative cross-sectional side view of a via that spans layers 22, 24, and 26 of display 14. The example of FIG. 4B in which via 28 spans each layer of display 14 is merely illustrative. If desired, via 28 may extend through only one, two, or more layers of display 14. For example, via 28 may be formed to span layers 22 and 24 without spanning sealant layer 26.

[0043] FIG. 5 is a diagram showing how a display may be provided with vias. Initially, a display substrate 22 may be provided. Substrate 22 may be a layer of polymer such as a layer of polyimide (as an example).

[0044] Via hole formation equipment 70 such as laser drilling equipment, mechanical drilling equipment, etching equipment (e.g., chemical or physical etching equipment), field ionization beam equipment, or other via hole formation equipment may be used to form one or more via holes such as via hole 72 in substrate 22.

[0045] Following formation of via holes such as via hole 72, conductive material deposition equipment such as metal plating equipment 74 may be used to form conductive structures for vias 28 such as conductive sidewalls 60. Traces such as contact trace 62 may also be formed on lower surface 64 of substrate 22. If desired, traces such as trace 29 of FIG. 2B may be formed on lower surface 64 of substrate 22.

[0046] Organic light-emitting diode (OLED) fabrication equipment 76 or other display fabrication equipment may be used to complete display 14. For example, OLED fabrication equipment 76 may be used to form thin-film transistor structures and interconnects in layer 24. Layer 24 may include organic emissive material and light-emitting diode structures that are used to form display pixels such as display pixels 48 of FIG. 3. A sealant layer such as sealant layer 26 (e.g., a polymer layer) may then be deposited over the front (upper) surface of display 14 to protect the structures of layer 24 (e.g., to help protect organic light-emitting material of layer 24 from moisture damage).

[0047] Additional processing equipment 78 may then be used to form electrical connections to additional circuitry 84. As shown in FIG. 5, conductive material 82 may be used in forming electrical connections between contacts such as contact 62 on display 14 (e.g., contacts on surface 64 of substrate 22) and associated contacts such as contact 80 on additional circuitry 84. Conductive material 82 may be solder, metal associated with a weld, part of a connector, conductive adhesive (e.g., anisotropic conductive film), or other suitable material for forming an electrical connection between via 28 and additional circuitry 84. Additional circuitry 84 may be a printed circuit or other circuitry. For example, additional circuitry 84 may be a flex circuit on which integrated circuits and/or other electrical components are mounted, a flex circuit cable that is attached to a printed circuit board with components, a rigid printed circuit board, or other suitable circuitry (see, e.g., the illustrative arrangements of FIGS. 1, 2, and 3).

[0048] FIGS. 6A and 6B are diagrams showing how vias and interconnection resources may be formed in an inactive region of a display. Initially, a display substrate such as substrate 22 may be provided.

[0049] Deposition equipment 102 may be used to deposit conductive layers 104 on the front and rear surfaces of substrate 22. Conductive layers 104 may be formed from any desired conductive material such as copper, titanium, molybdenum, indium, palladium, rhodium, gold, silver, platinum, or other conductive materials. If desired, optional protective layers 106 may be deposited over conductive layers 104 using deposition equipment 102. For example, it may be desirable to coat conductive layers 104 that are formed from copper or other heavy metals with protective layers 106, because copper and other heavy metals can potentially diffuse into and contaminate other materials such as silicon. Protective layers 106 may be formed from conductive or non-conductive materials. For example, protective layers 106 may be formed from a conductive titanium layer that helps block diffusion of the materials of conductive layers 104 into neighboring materials. As another example, protective layers 106 may be formed similar to sealant layer 26 of FIG. 5.

[0050] In a subsequent step, via hole formation equipment 70 may be used to form opening 72 in substrate 22 and conductive layers 104 (and, if desired, any associated protective layers 106). Plating and lithography equipment 105 may then be used to form conductive structures for vias 28 (e.g., conductive sidewalls 60 and contacts 62) and traces such as traces 106. Lithography equipment 105 may be used to selectively remove portions of conductive layers 104 to form traces 106 and contacts 62. Traces 106 may be used to convey display signals for the display. Lithography equipment 105 may also be used to remove conductive materials that cover region 33 of substrate 22 (e.g., so that region 33 of substrate 22 is exposed). Region 33 may serve as an active display region.

[0051] Organic light-emitting diode fabrication equipment 76 may be subsequently used to complete active region 33 by forming layers 24 and 26. For example, OLED fabrication equipment 76 may be used to form thin-film transistor structures and organic emissive material and light-emitting diode structures in layer 24 and subsequently deposit a sealant layer that covers active region 26. If desired, sealant layer 26 may be deposited to extend over part or all of inactive region 31 (e.g., regions that do not include active pixels). Additional processing equipment 78 may then be used to form electrical connections to additional circuitry 84 using conductive material 82 (e.g., similar to FIG. 5).

[0052] The examples of FIGS. 5, 6A, and 6B in which vias 28 are formed before completing display 14 are merely illustrative. FIG. 7 is an illustrative diagram in which via 28 may be formed after completion of display 14.

[0053] In the example of FIG. 7, a substrate 22 may be initially provided. Organic light-emission diode fabrication equipment may be used to complete display 14 by forming thin-film transistor structures and light-emitting diode structures in layer 24 and covering layer 24 with sealant layer 26. Completed display 14 may include active region 33 (e.g., a region including active pixels) and inactive region 31 (e.g., a region without any active pixels). Inactive region 31 may be formed along the periphery of active region 33. Via 28 may be subsequently formed using via formation equipment 112. Via formation equipment 112 may, for example, include via hole formation equipment 70 and plating equipment 74 of FIG. 5.

[0054] Via 28 of FIG. 7 may be formed extending through layers 24 and 26 of display 14. Via 28 may be electrically coupled to transistor structures or traces in layer 24 and may be used to convey display signals to transistor structures and light-emitting diode structures of layer 24 (e.g., from a driver circuit).

[0055] As shown in FIG. 8, organic light-emission diode fabrication equipment 76 may be used to complete display 14 by forming layers 24 and 26 over a region 122 of substrate 22 while leaving an exposed portion of substrate 22 for via formation. Region 122 of substrate 22 may correspond to an active region of display 14 on which layers 24 and 26 are formed. Protective layer 26 may extend somewhat beyond the edge of light-emitting layer 24. Region 124 of substrate 22 be an inactive region of display 14 and may remain exposed after completion of display 14. Via 28 may be subsequently formed in exposed region 124 of substrate 22 using via formation equipment 112.

[0056] As shown in FIG. 9, vias such as via 28 may be formed through only a portion of the layers of display 14. Via 28 of FIG. 9 may sometimes be referred to as a blind via, because via 28 is exposed only on a single (e.g., rear) surface

of display 14. After completion of display 14 using organic light-emitting diode fabrication equipment 76 to form layers 24 and 26 over substrate 22, via formation equipment 112 may be used to form via 28 extending only through layers 22 and 24. For example, via formation equipment 112 may include via hole formation equipment that can be used to drill a via hole from the rear surface of substrate 22 to extend through substrate 22 and layer 24. As another example, etching equipment may be used to etch a via hole through layers 22 and 24. In this scenario, the etching process may be timed based on a desired depth for the via hole. If desired, the via hole may extend through a portion of sealant layer 26. Conductive via structures may be subsequently formed in the via hole (e.g., via formation equipment 112 may be used to perform electroplating or other fabrication techniques).

[0057] If desired, display 14 may be provided with portions (regions) in which light is emitted through substrate 22 (sometimes referred to as bottom surface emission portions or bottom emission portions) and portions in which light is directly emitted by a light emission layer without passing through substrate 22 (sometimes referred to as top surface emission portions or top emission portions). In other words, bottom surface emission portions include light-emitting structures located at the bottom surface of display 14 that emit light through the top surface of display 14, whereas top surface emission portions include light-emitting structures located at the top surface of display 14 that emit light directly through the top surface.

[0058] FIG. 10 is an illustrative arrangement in which display 14 is provided with a top surface emission portion 24A and a bottom surface emission portion 24B. Top surface emission portion 24A and bottom surface emission portion 24B may each include organic emissive materials and organic light-emitting diode structures and thin film transistor structures. Top surface emission portion 24A may directly produce light 132 that does not pass through substrate 22, whereas bottom surface emission portion 24B may produce light 132 that passes through substrate 22. In the example of FIG. 10, substrate 22 may be formed from transparent materials such as glass, plastics (e.g., polymers such as polyimide), sapphire, transparent acrylics, or other transparent substrate materials.

[0059] Vias 28 may be formed on the rear surface of substrate 22 underneath top surface emission portion 24A. Vias 28 may be electrically connected to top surface emission region 24A, bottom surface emission region 24B, and printed circuit 32 (e.g., vias 28 may be used to convey display signals between top surface emission region 24A, bottom surface emission region 24B, and printed circuit 32). Vias 28 may be coupled to bottom surface emission region 24B via traces 29 formed on the rear surface of substrate 22.

[0060] If desired, display vias may be formed as conductive rods that are inserted through a display substrate. FIG. 11 is an illustrative diagram showing how vias 28 may be formed from conductive rods such as wires. An initially provided substrate 22 may be heated using heating equipment 140. Heating equipment 140 may include oil-based heating tools, gas-based heating tools, electrical-based heating tools, or any other heating tools suitable for heating the materials of substrate 22. Heating equipment 140 may, if desired, also include equipment used to apply pressure to substrate 22. Substrate 22 may be heated so that the materials of substrate 22 are partially melted (e.g., partially or completely liquefied). Support structures (not shown) may be used to maintain a desired structure of display 22 during a partially-melted state.

[0061] Wire insertion equipment 144 may be used to insert wires 142 or other conductive structures such as conductive rods into melted substrate 22. Wires 142 may be formed from any desired conductive materials. As substrate 22 cools, the materials of substrate 22 may solidify around wires 142. If desired, substrate 22 may be cooled using cooling equipment (not shown). Excess portions of wires 142 may then be removed using cutting equipment 146 to form vias 28. OLED fabrication equipment such as equipment 76 of FIG. 5 may be subsequently used to form display layers such as light-emitting display layer 24 and sealant layer 26.

[0062] The foregoing is merely illustrative of the principles of this invention and various modifications can be made by those skilled in the art without departing from the scope and spirit of the invention.

What is claimed is:

1. An electronic device display, comprising:
  - a transparent display substrate having front and rear surfaces;
  - a front surface emission region on the front surface of the transparent display substrate that emits light from the front surface; and
  - a rear surface emission region on the rear surface of the transparent display substrate that emits light through the transparent display substrate.
2. The electronic device display defined in claim 1 wherein the front surface emission region and the rear surface emission region include organic light-emitting diode structures.
3. The electronic device display defined in claim 1 further comprising:
  - a via formed in the transparent display substrate that extends from the front surface emission region to the rear surface of the transparent display substrate.
4. The electronic device display defined in claim 3 further comprising:
  - a flexible printed circuit that is coupled to the via at the rear surface of the transparent display substrate; and
  - driver circuitry, wherein the flexible printed circuit conveys a display signal between the driver circuitry and the via.
5. The electronic device display defined in claim 1 wherein the front surface emission region comprises a first light-emitting layer and wherein the rear surface emission region comprises a second light-emitting layer.
6. The electronic device display defined in claim 5 further comprising:
  - a via that extends through the transparent display substrate, wherein the first light-emitting layer overlaps the via.
7. The electronic device display defined in claim 5 wherein the first and second light-emitting layers comprise light-emitting diode structures.
8. The electronic device display defined in claim 5 further comprising:
  - a flexible printed circuit that transmits display signals to the first and second light-emitting layers.
9. The electronic device display defined in claim 8 further comprising:
  - a conductive via that extends through the display substrate and that transmits the display signals from the flexible printed circuit to the first light-emitting layer; and
  - a conductive trace on the rear surface of the transparent display substrate that transmits the display signals from the flexible printed circuit to the second light-emitting layer.

**10.** The electronic device display defined in claim **9** further comprising:

display driver circuitry, wherein the flexible printed circuit transmits the display signals from the display driver circuitry to the conductive via and the conductive trace.

**11.** A display comprising:

a display substrate;

a light-emitting layer on the display substrate;

a via that extends through the display substrate; and

a sealant layer formed over the light-emitting layer, wherein the sealant layer overlaps the via.

**12.** The display defined in claim **11** wherein the light-emitting layer comprises light-emitting diode structures.

**13.** The display defined in claim **11** wherein the via extends through display substrate without extending through the light-emitting layer.

**14.** The display defined in claim **11** wherein the via extends through the display substrate and the light-emitting layer without extending through the sealant layer.

**15.** The display defined in claim **11** wherein the display substrate has first and second opposing surfaces and wherein the light-emitting layer and the sealant layer are formed on the first surface, the display further comprising:

conductive material in the via; and

a metal trace on the second surface, wherein the metal trace is shorted to the conductive material in the via.

**16.** The display defined in claim **11** further comprising: an active region that includes display pixels, wherein the via is formed in the active region.

**17.** A display comprising:

a display substrate; and

a conductive rod that extends at least partially through the display substrate to form a via that is completely filled by the conductive rod.

**18.** The display defined in claim **17** wherein the display substrate comprises first and second opposing surfaces, and wherein the conductive rod extends from the first surface to the second surface.

**19.** The display defined in claim **18** wherein the conductive rod extends through at least one of the first and second opposing surfaces.

**20.** The display defined in claim **17**, further comprising:

a light-emitting layer on the display substrate, wherein the light-emitting layer is electrically coupled to the conductive rod.

\* \* \* \* \*

专利名称(译)	显示Vias		
公开(公告)号	<a href="#">US20160088692A1</a>	公开(公告)日	2016-03-24
申请号	US14/866624	申请日	2015-09-25
[标]申请(专利权)人(译)	苹果公司		
申请(专利权)人(译)	苹果公司.		
当前申请(专利权)人(译)	苹果公司.		
[标]发明人	WEBER DOUGLAS J ROTHKOPF FLETCHER R DRZAIC PAUL S DABOV TEODOR WRIGHT DEREK W MYERS SCOTT A		
发明人	WEBER, DOUGLAS, J. ROTHKOPF, FLETCHER, R. DRZAIC, PAUL, S. DABOV, TEODOR WRIGHT, DEREK, W. MYERS, SCOTT, A.		
IPC分类号	H05B33/06 H05B33/04 H05B33/12 H05K1/11		
CPC分类号	H05B33/06 H05K1/115 H05B33/04 H05B33/12 H01L27/3297 H01L51/56 H01L2227/32 H01L2251/56 H05B33/02 H05B33/10		
优先权	61/664060 2012-06-25 US		
其他公开文献	US9974122		
外部链接	<a href="#">Espacenet</a> <a href="#">USPTO</a>		

摘要(译)

电子设备可以包括显示器。显示器可以是有机发光二极管显示器。有机发光二极管显示器可以具有基层，有机发光二极管结构层和密封剂层。可以在衬底层中形成通孔。可以在显示完成之前或者完成显示之后形成通孔。可以使用电镀或其它金属沉积技术用金属填充通孔。通孔可以连接到显示器的后表面上的触点。通孔可以位于显示器的有源区域或显示器的无源区域中。显示器可以包括顶表面发射部分和底表面发射部分。

emitting diode display may have a substrate layer, a layer of organic light-emitting diode structures, and a layer of sealant. Vias may be formed in the substrate layer. The vias may be formed before completion of the display or after completion